

The Geomagnetic Field Experiment LaACES UNO 2012-2013

TEAM MEMBERS:

Nick Studer

Benjamin Wilkins

Scott Simonsen

Brian Kustra

Britt Aguda

Matthew Hellmers

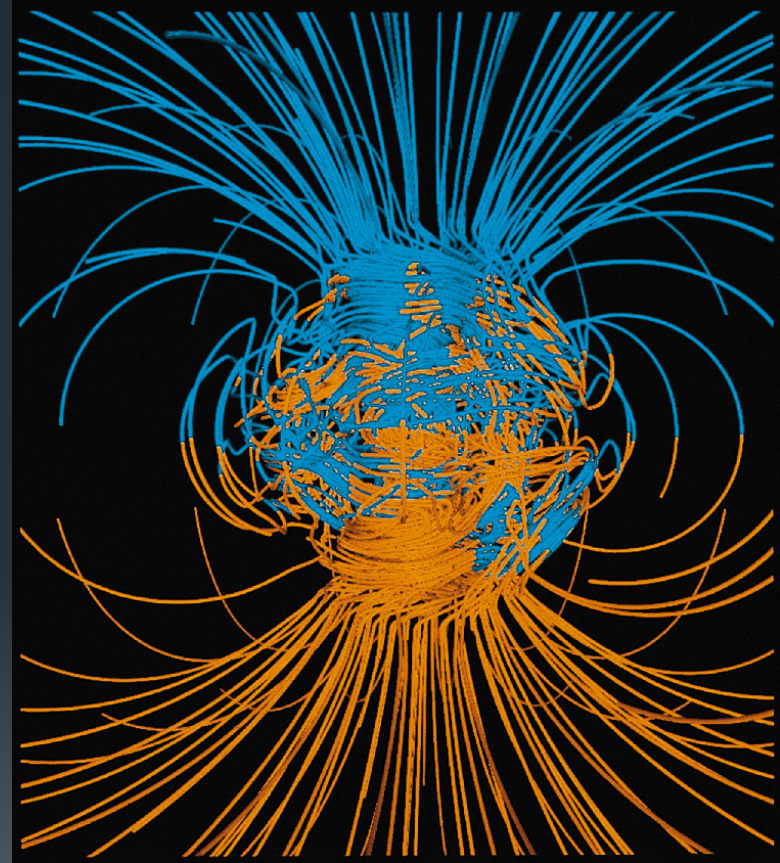

Geomagnetic field computer simulation.
Source: psc.edu

Mission Goal

- Measure the magnitude of the Geomagnetic field as a function of altitude.
- Compare measured results against mathematical models.
- Look for extraterrestrial interferences, likely due to solar cycle.

Science Background

- Earth has an intrinsic magnetic field due to movement of molten metal core.
- Magnetic influence is stronger near the core, weaker with radial distance.
- Field is not constant in strength or direction over long (millions of years) time scales.
- Can be modeled as a magnetic dipole.

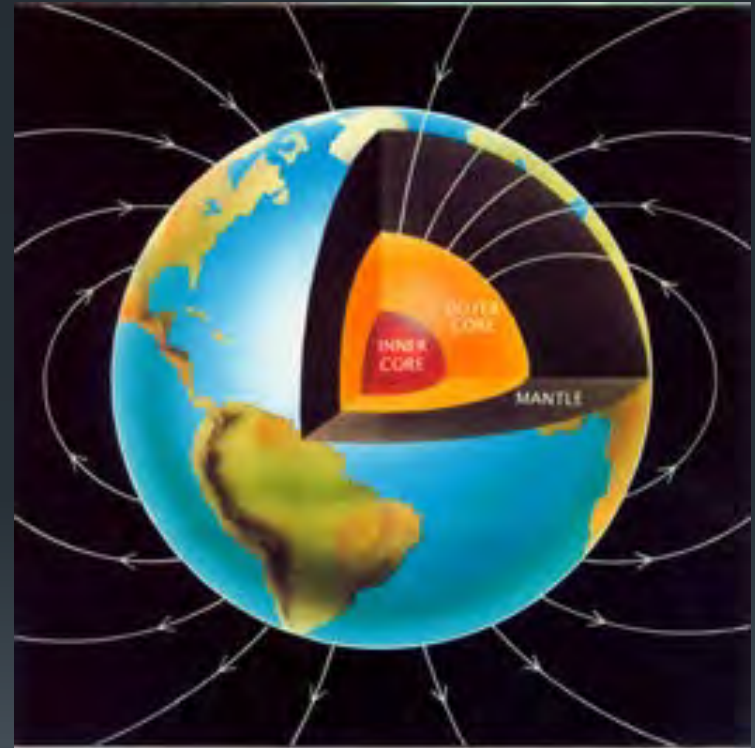

Geomagnetic field diagram
Src: geomag.usgs.gov

Science Background

- Two mathematical models for comparison:
 - World Magnetic Model (WMM)
 - International Geomagnetic Reference Field (IGRF)
- Both models agree up to higher altitudes.
- Neither model accounts for solar cycle.

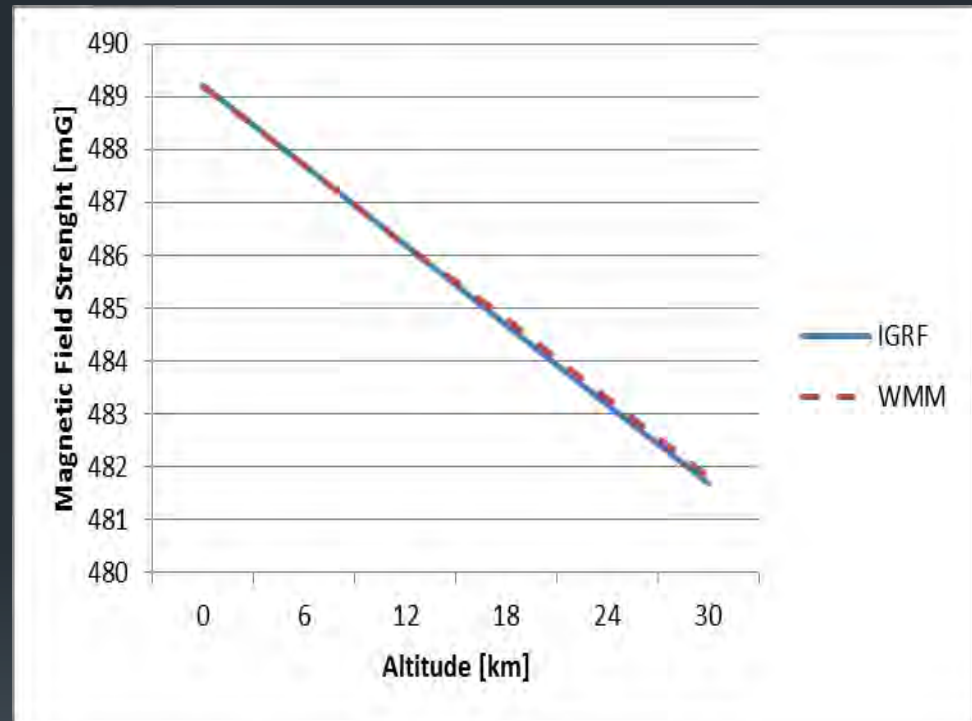

Model predictions for magnetic field strength over the expected flight altitudes.

Science Background



Expected peak of current solar cycle:

May 2013

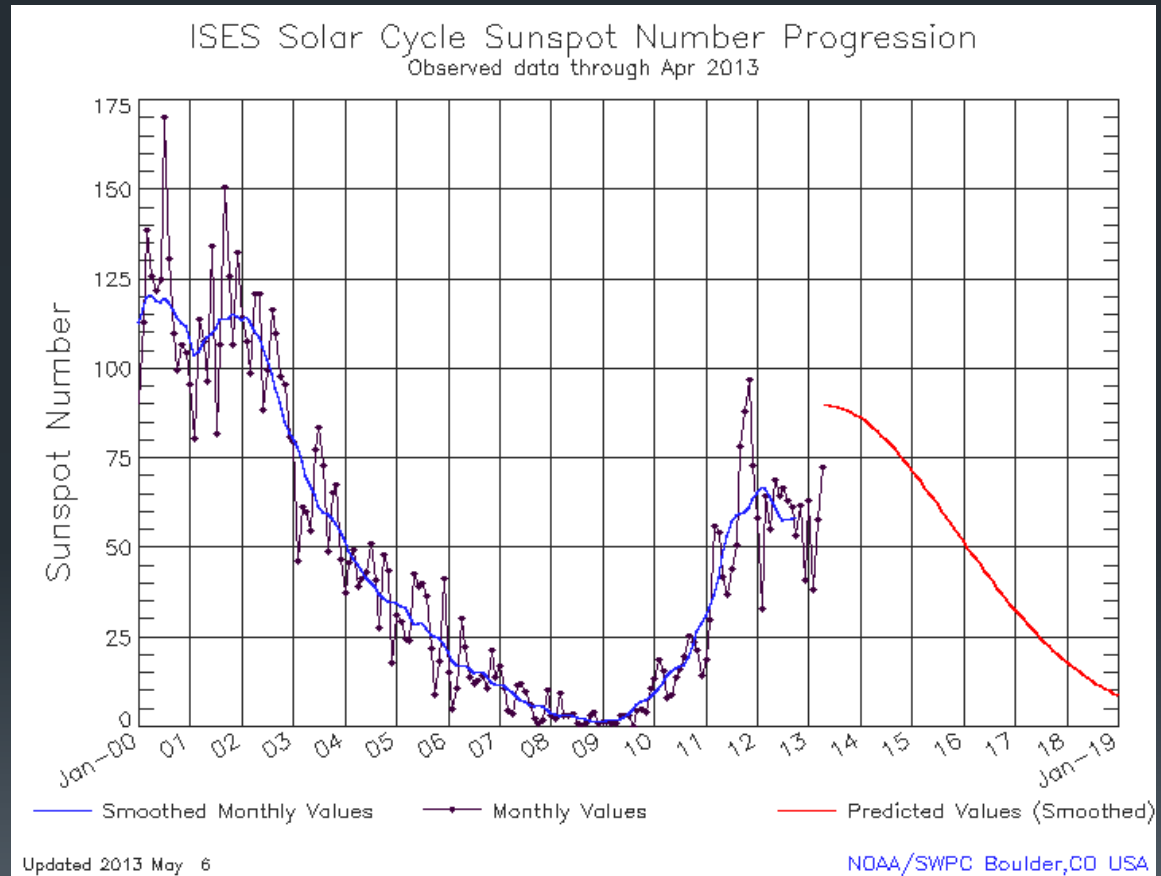

Past solar activity and prediction for future activity.
Source: <http://noaa.gov>

Science Background

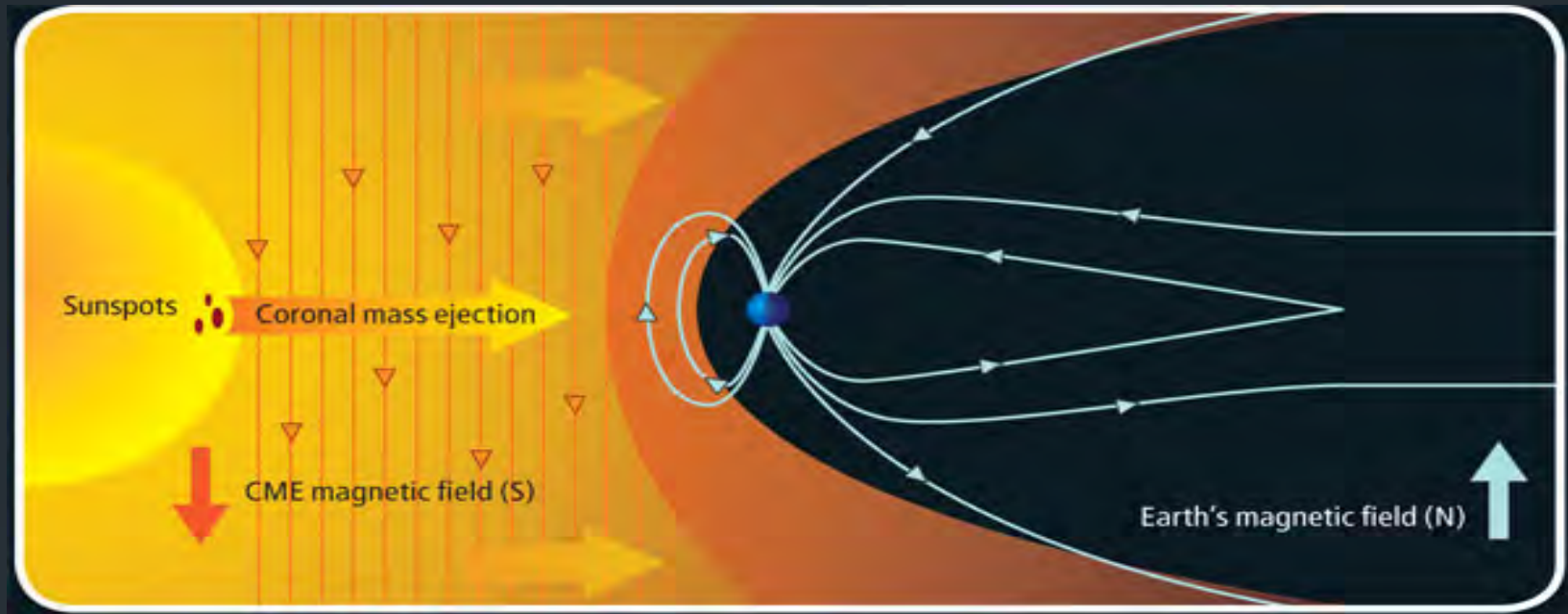

- During solar maxima, charged particles can distort the geomagnetic field.
- Monitoring solar activity the day of launch should allow us to correlate data with the solar cycle.

Magnetic field distortion due to a coronal mass ejection.
Source: scientificamerican.com

Objectives



- Science Objectives

- Measure Earth's magnetic field as a function of altitude.
- Compare against mathematical models.
- Attempt to observe solar influences.

- Technical Objectives

- Ensure reliable data (eliminate noise, power failure, etc.).
- Keep components functioning (protected from environmental conditions).
- Record all sensor data in proper format; do not overwrite and log entire flight.

Objectives

Technical Objectives – cont.d

- Record external and internal temperature data to assess insulation quality.
- Record altitude to correlate magnetic data with.
- Measure magnetic field magnitude with resolution $< 1\text{mG}$.

Technical Requirements

- Data storage must be large enough to accommodate ~4 hours of flight data.
- Equipment should be maintained within operating temperature range.
- Power supply should be adequate to operate all devices, especially in cold temperatures, for the full duration of flight.
- Magnetometer should be removed from magnetic interference caused by electronics.
- Maintain weight under a fixed budget.

Principle of Operation:

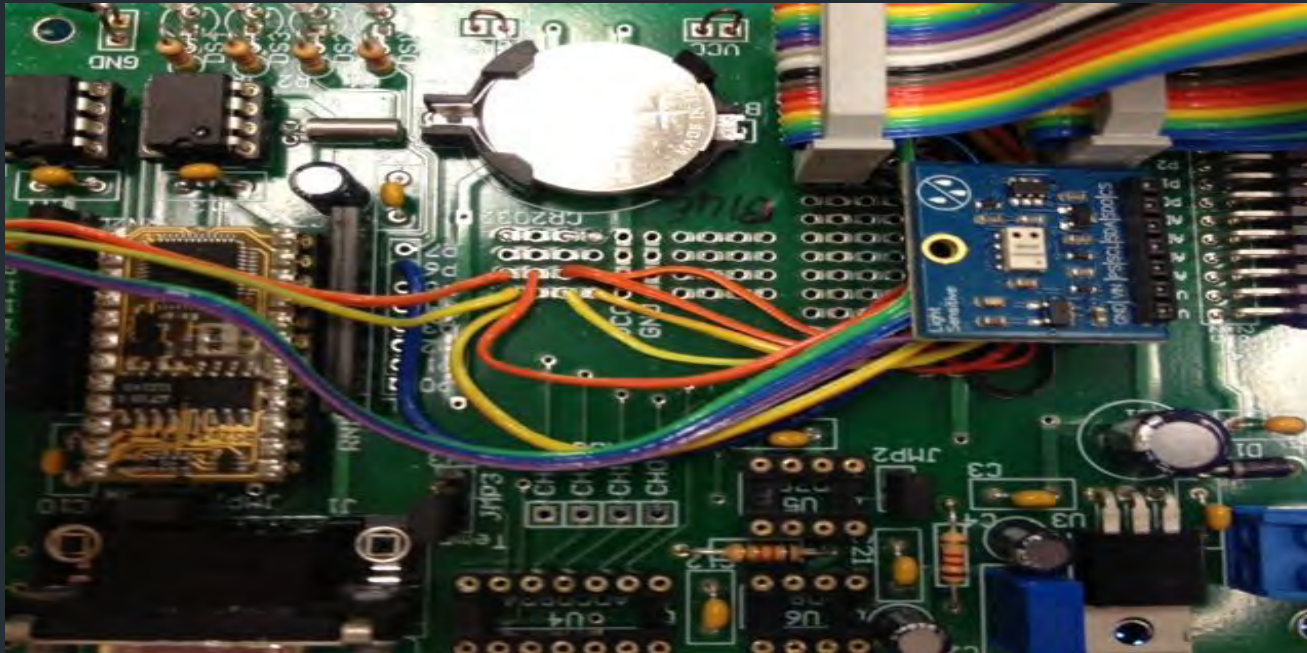

- The payload's circuit is designed to log and record data given by several different sensors.
- The circuit interfaces with an altimeter, a magnetometer, and a multi-channel RTD circuit and saves the data from the sensors on an EEPROM using a Basic Stamp module.
- The Basic Stamp IC includes a real time clock with a backup battery for time stamping purposes.

System Design:

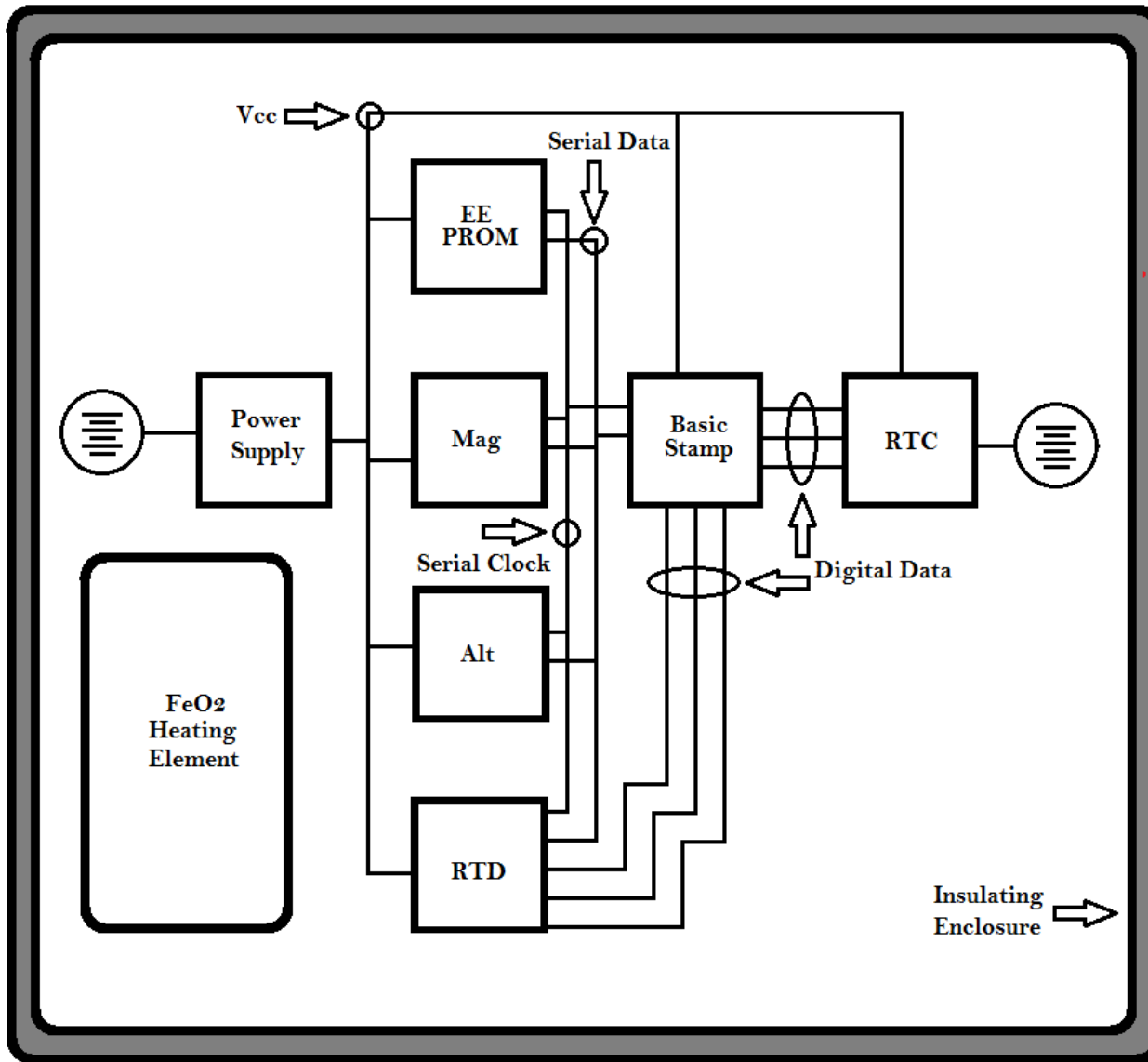

Mechanical Design

External

- Cube shape with boom extension for magnetometer.
- Constructed of Owens Corning Foamular $\frac{3}{4}$ " thick insulation board.
- Measures 20cm x 20cm x 20cm with interfacing straws 17cm apart.
- 15 cm boom for magnetometer.

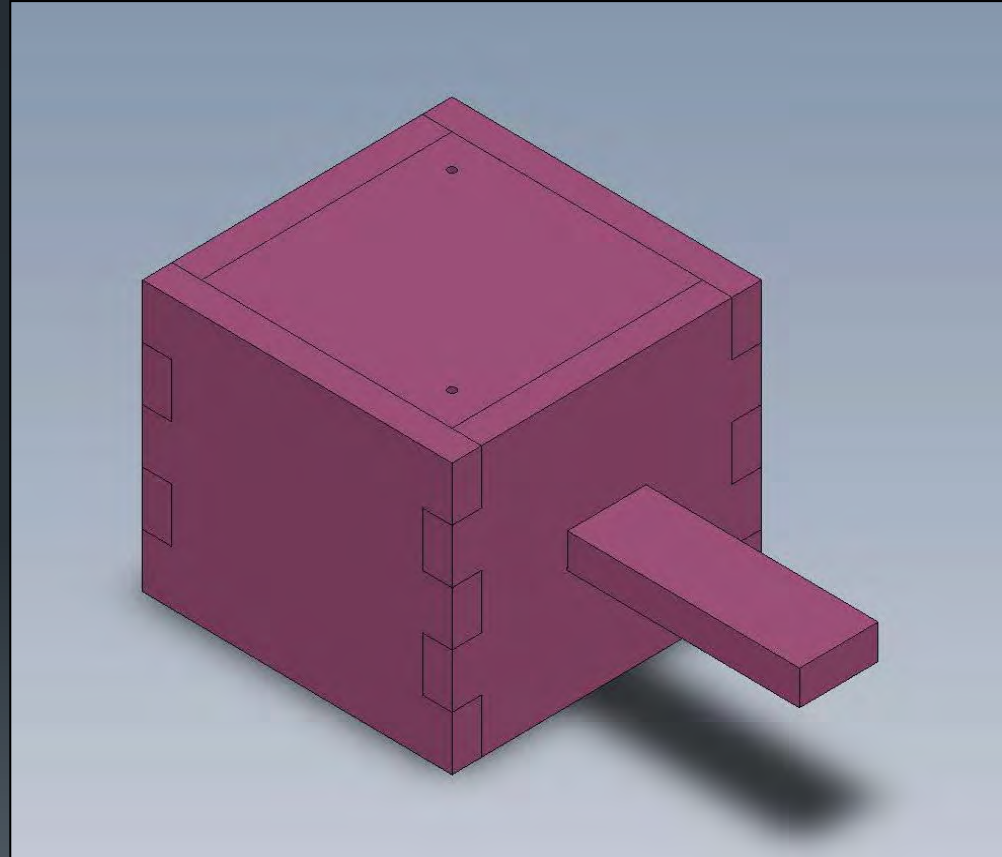

Mechanical Design

Altimeter on BalloonSat

Internal

- Interior consists of twelve layers of TA-301 polyimide foam stacked together.
- Foam stack wrapped in two layers of Mylar blanket.
- HOLLOWED core for circuit board space.
- Balloonsat is separated from RTD circuit by a layer of the same foam.

Magnetometer

Internal RTD

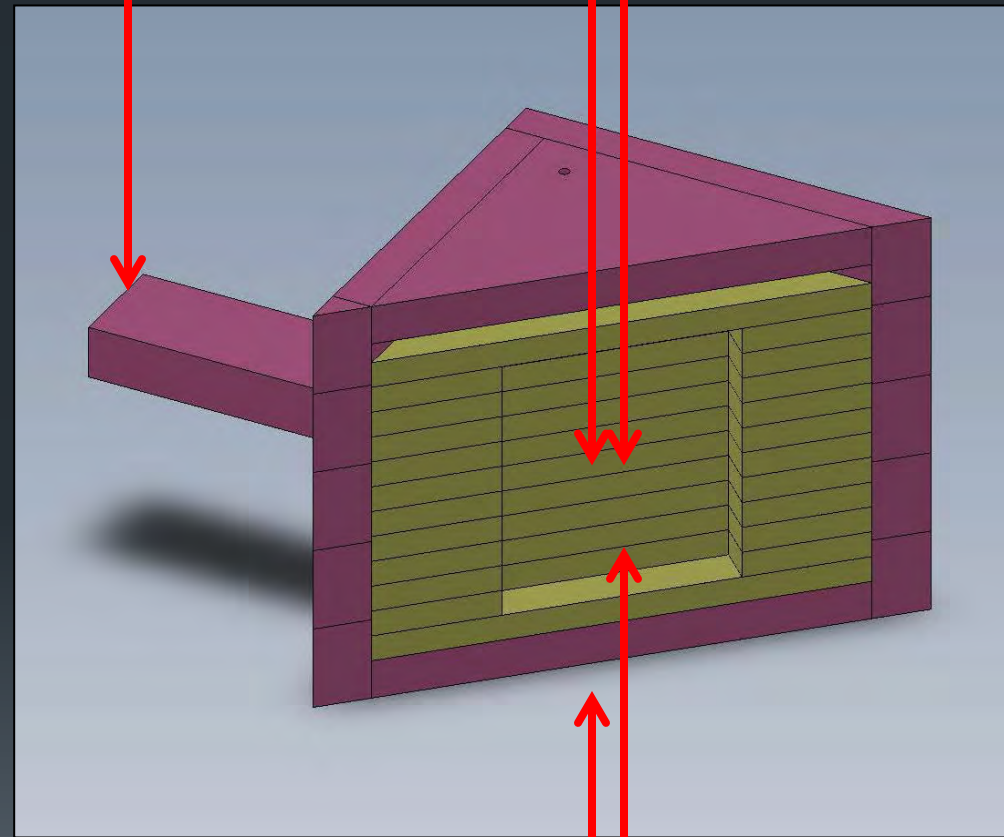

External RTD

Heating pack

Sensors and Electronics

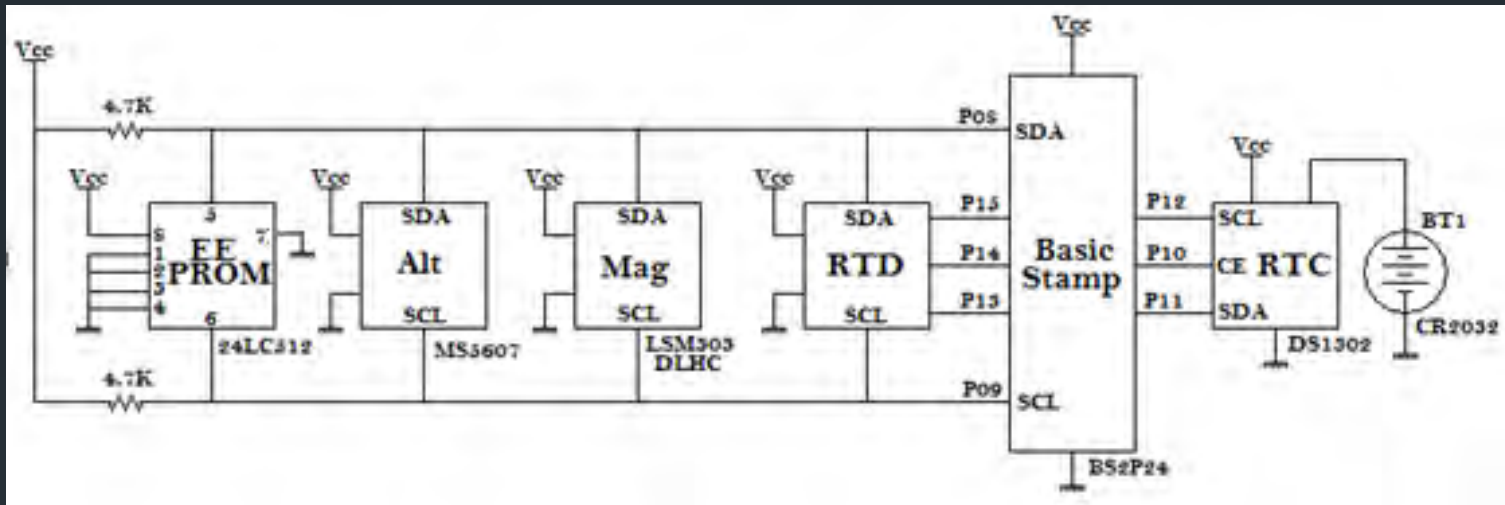

- Basic Stamp BS2P24 microcontroller regulates and records sensor data.
- All sensor data is transported over the serial data bus using an I²C protocol.
- Sensor Data is recorded on a 24LC512 EEPROM by the Basic Stamp using I²C protocol. (512 kbit memory)
- The Basic Stamp module includes a real time clock with a back up battery for precise uninterrupted data collection.

Sensors and Electronics --RTD Module

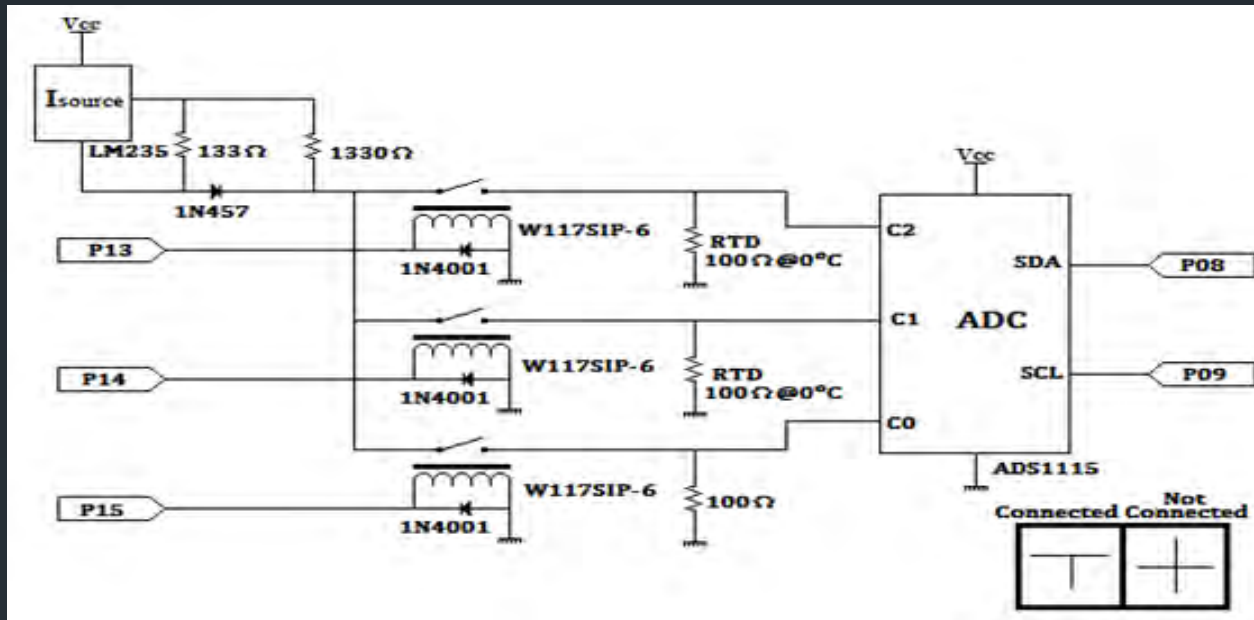

- The input signals from the Basic Stamp controls relays that determines the current through the RTDs and the reference resistor.
- The voltage across each resistor is detected by the ADS1115 which converts and conveys the data back to the Basic Stamp.
- The current from the source can be calculated from the voltage drop and resistance of the reference resistor.
- The resistance of the RTD can be determined using the referenced current and the measured voltage across the RTDs; this resistance is proportional to temperature.

Sensors and Electronics -- Power

The payload is powered by an Energizer Advanced Lithium 9V (LA 522).

- Operating temperature -40C to 60C.
- Low temperature conditions performance data not available.
- Previously listed power was considering maximum, continuous load.
 - Expected average load is ~35mA
 - We require ~175 mAh
- Standard mAh performance above 25mA is approximately 750mAh.
- De-rating by 75% due to low temperatures, we have ~190 mAh

Milliamp-Hours Performance (21°C)

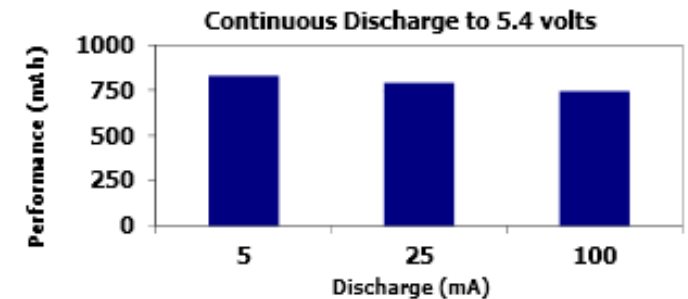

Typical Discharge Performance (21°C)

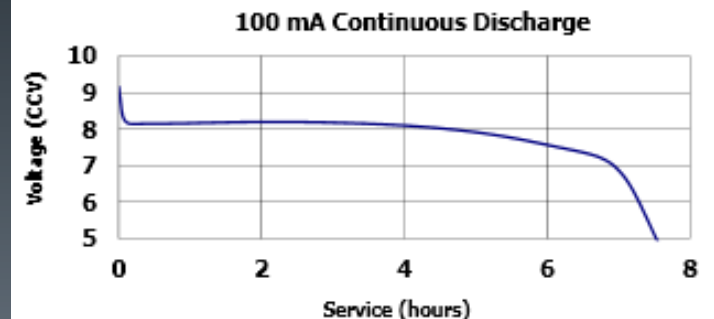
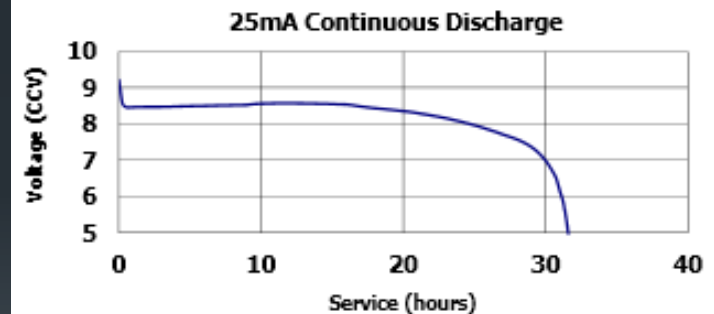

Software Design

Main software packages are the pre-flight and in-flight programs.

Pre-flight

- Clears EEPROM data.
- Sets memory address indexing variable to 0 on the Basic Stamp memory.
- Outputs current raw data values of all sensors to determine proper functionality.
- Sets real-time clock.

In-flight

- Sets settings for all components.
- Reads sensor data and stores in buffer variables.
- Writes collected data to onboard EEPROM.
- Terminates when EEPROM full.

A simple post-flight program consists of outputting the contents of the EEPROM to terminal for extraction to Microsoft Excel for analysis.

Calibrations

- Resistance temperature devices were calibrated using 3 reference temperature points:
 - -78C (Dry Ice/Acetone), 0C (Ice Water), 100C (Boiling Water)



-78 C Reference

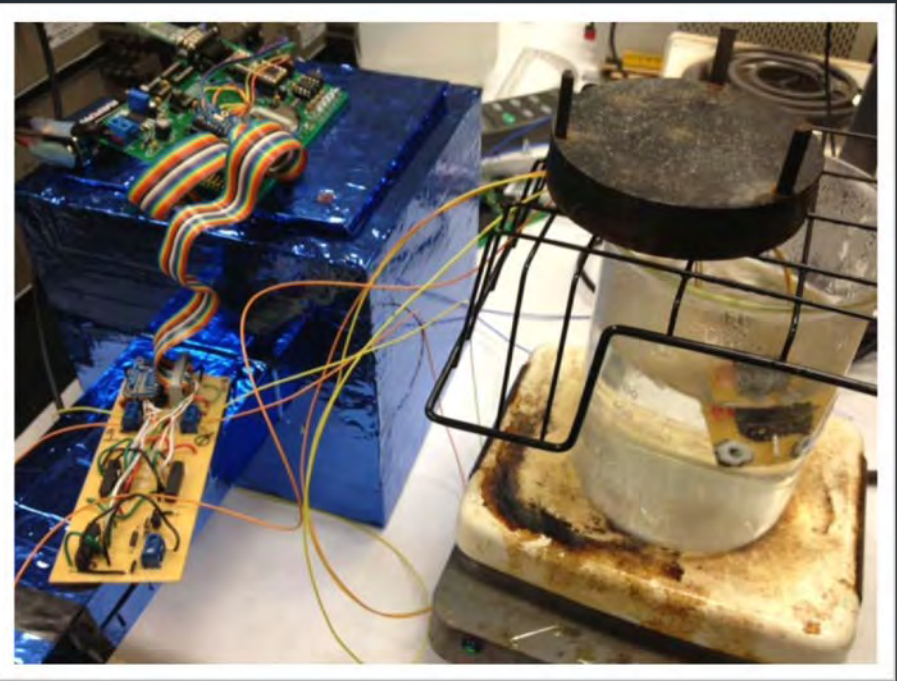

100 C Reference

Calibrations – Cont.

- Altimeter arrived with factory calibrations, pressure readings were taken and compared to reported local weather conditions. Expected and measured values matched.
- Magnetometer arrived with factory calibrations. Measured values matched predicted local values.

Pressure vs. Time

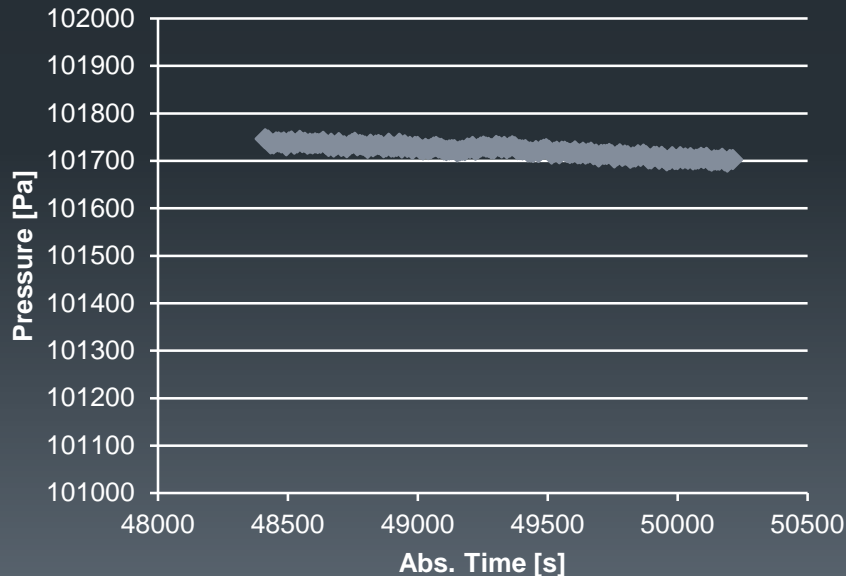

Magnetic Field Magnitude vs. Time

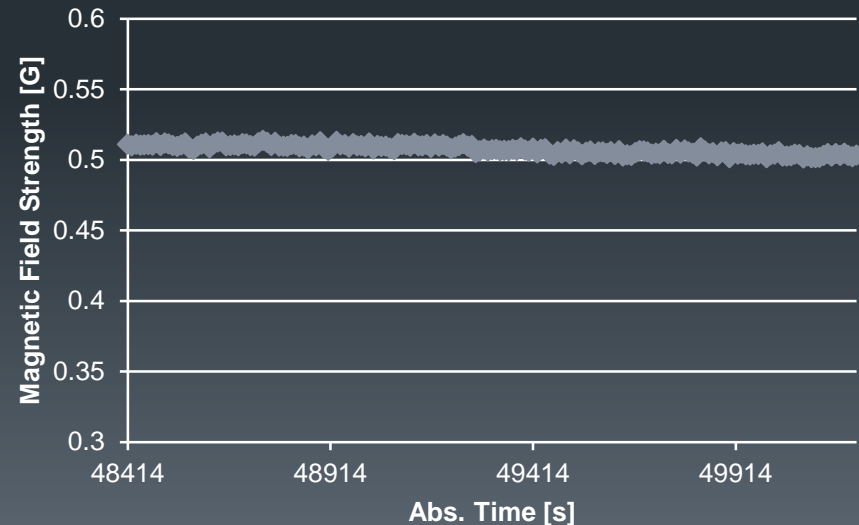

Testing

- 3 main tests were performed on the payload package:
 - Thermal Testing:
 - Place payload in cold (-50 C) environment over long (~3 hour) time frame.
 - Verify continuous functionality of all components.
 - Shock Testing:
 - Drop payload from 12 ft.
 - Verify structural integrity and continual data collection.
 - “Spin” Testing:
 - Attempt to mimic most chaotic movement expected from flight.
 - Verify the error induced on sensor data is manageable.

Testing

- Thermal tests repeated a total of 5 times, with 2 additional tests at standard conditions.
 - Multiple programming and electronic problems were diagnosed and repaired by this process.
- Shock test done once. Test indicated structural integrity remained.
- Spin test done once. Data indicated spin error is manageable.

Testing -- Thermal

- Internal heating and insulation were tested multiple times for up to 3 hours at -60 C to ensure components will function as required in near space environments.

Temperature in chamber vs time

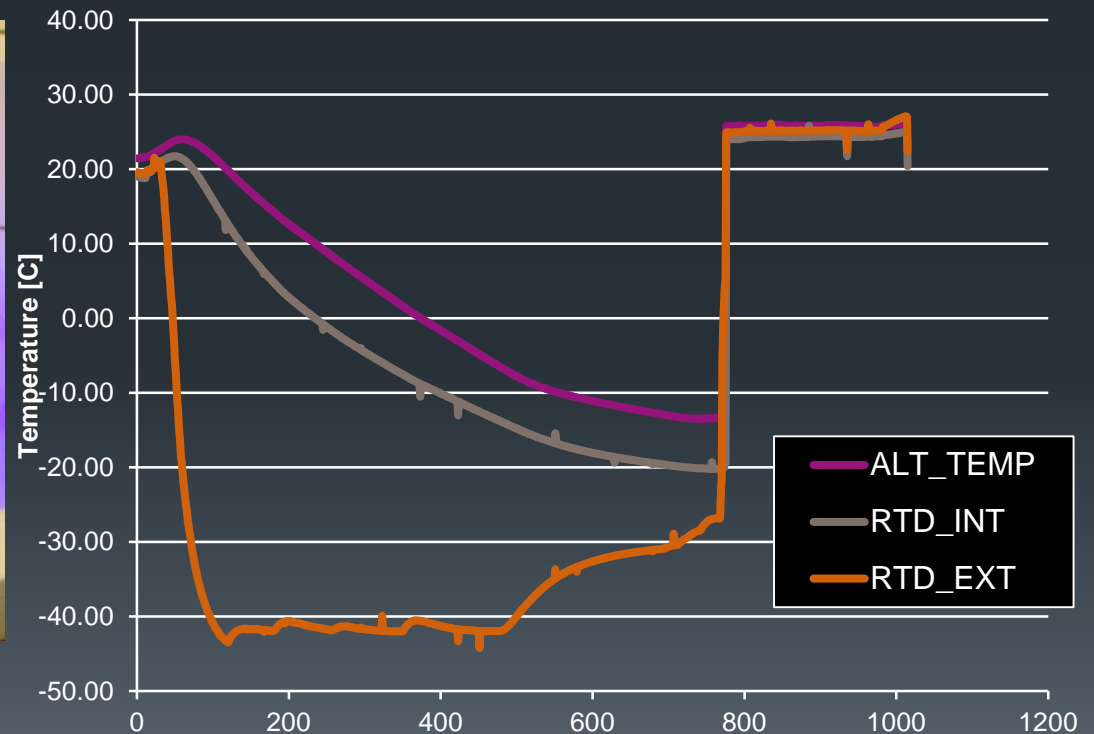

x-axis units are data point numbers. We had a RTC failure this run, but it ran ~2 hours.

Testing – Shock and Spin

- Drop testing was performed from a height of 12 feet, data collection and structural integrity remained constant.
- Spin testing was performed by suspending the payload in the air and spinning it rapidly along with changing direction as chaotically as possible. Data collection remained continuous, and values remained relatively constant. Control data was collected before and after.



**Averaged Data -- Magnetic Field
v Time**

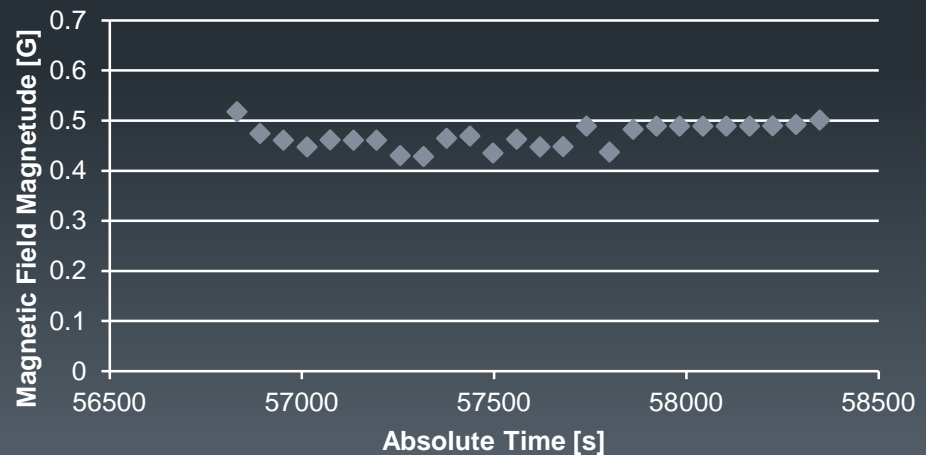

Testing -- Conclusions

- All tests were successfully completed.
- Thermal testing indicates that our insulation is sufficient, especially so with addition of our heating element.
- Shock tests conclude that our structural design performs as required to protect internal equipment.
- Spin test verifies that rotational error induced on the magnetometer data can be sufficiently averaged out.

Post-Flight: The Results

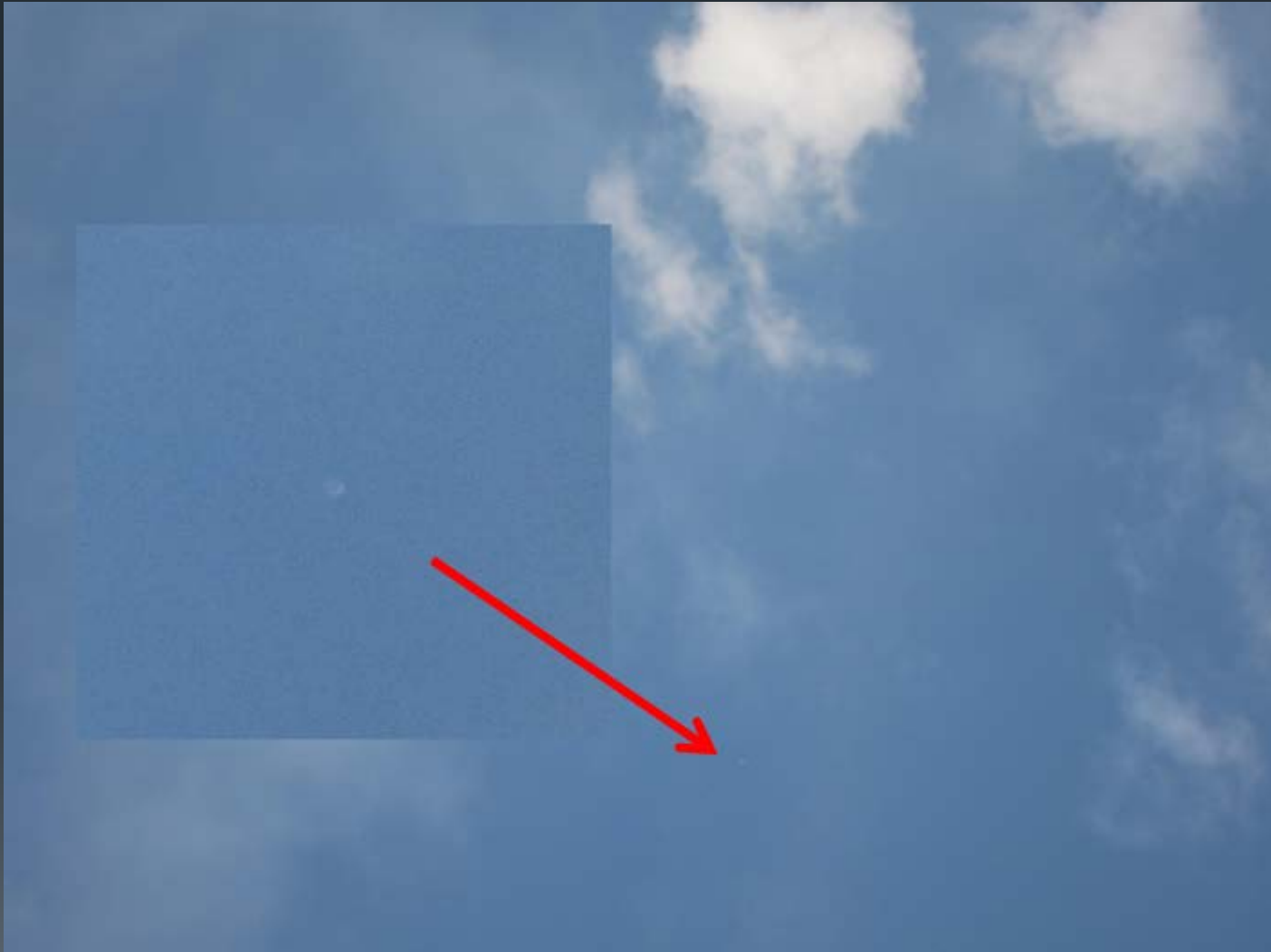

Observations

- Payload performed (mostly) as intended.
 - Insulation kept payload in safe temperatures.
 - Payload box remained well intact.
 - Data collected and stored properly.
 - A problem with the Basic Stamp occurred after flight. I/O ceased functioning.
- Intrinsic resolution not good enough to measure the predicted change.
- Data did not fit predictions, but a clear trend was observed.

Intrinsic Magnetic Resolution

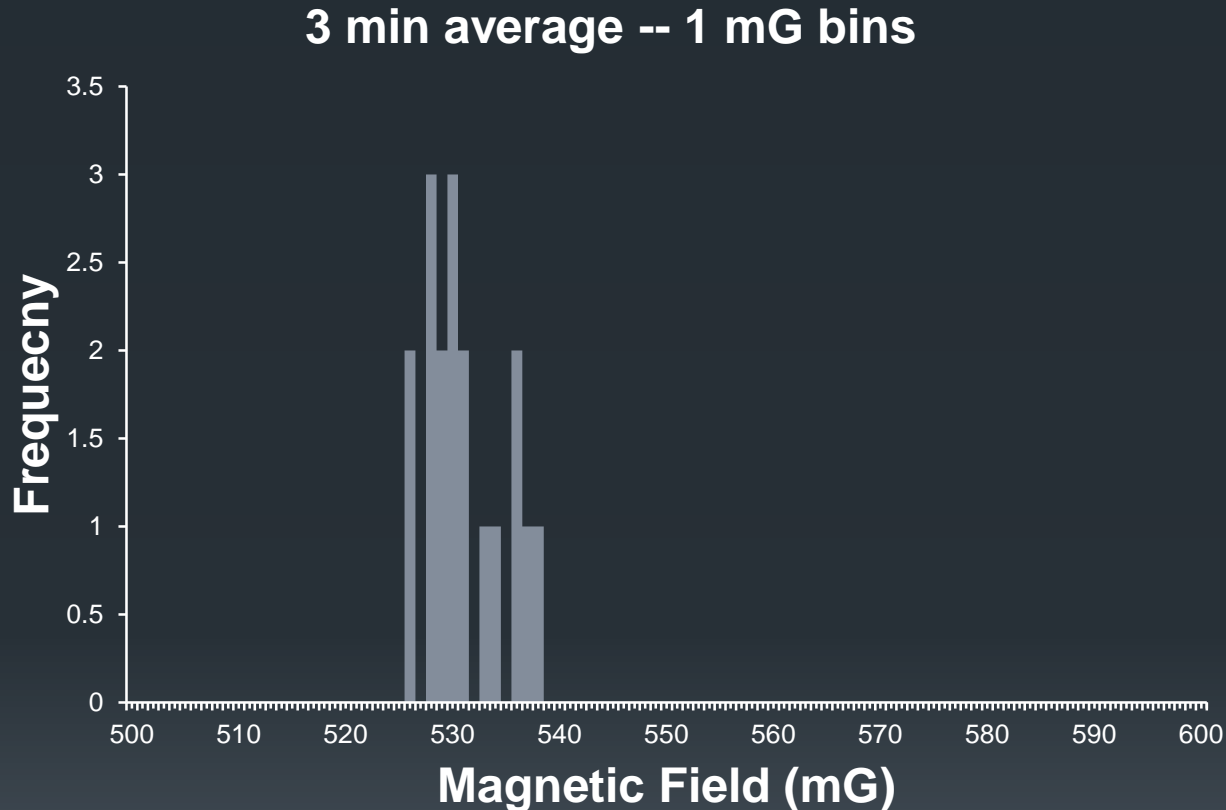

- At best, our sensor has ~10mG resolution.
- Movement reduces our capability considerably.

Raw Magnetic Field Results



Magnetic Field vs Time

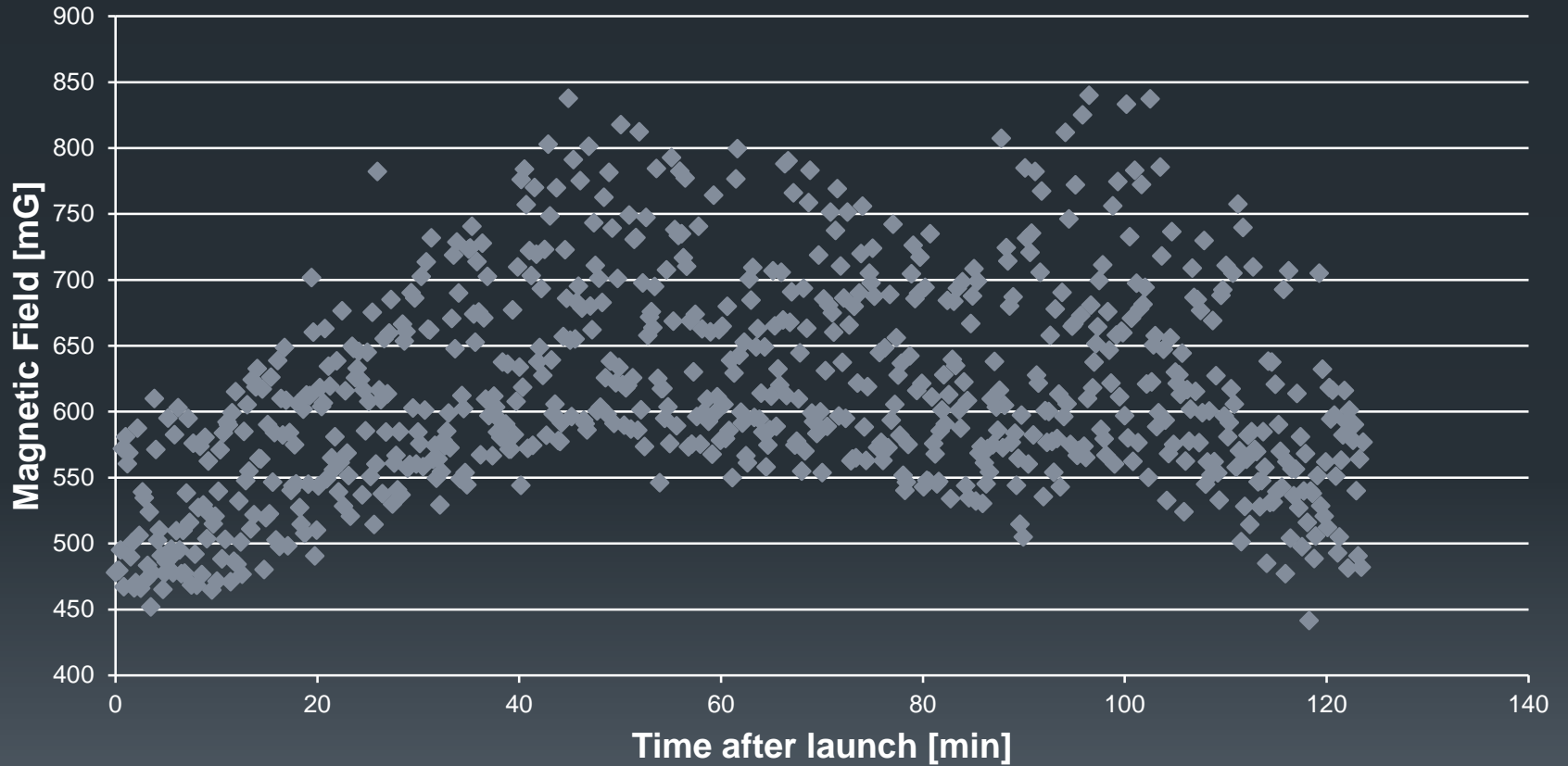

Averaged Magnetic Field Results

Magnetic Field vs Time averaged over 3 minute intervals

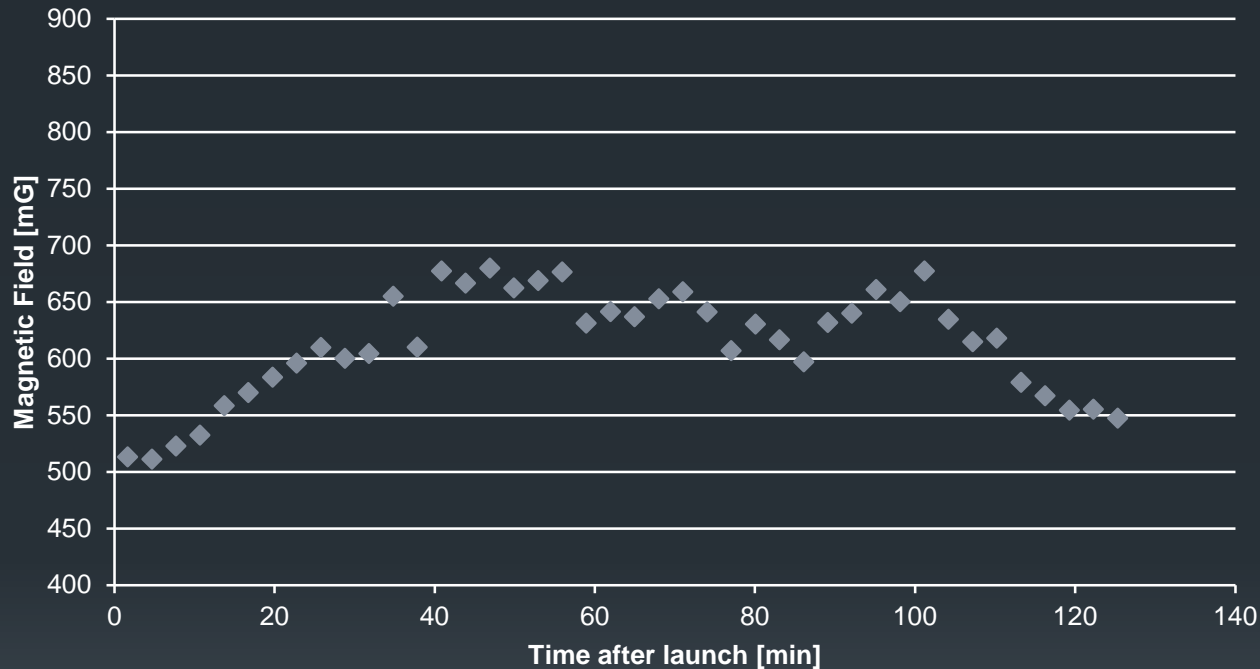

- Noisy signal, due to movement and intrinsic noise.
 - Averaging over 3 minutes helps considerably.
- Two distinct peaks.
 - Correspond to same altitude on ascent and descent.

Possible Explanations

- Internal temperature
 - Could temperature have affected magnetic data for any reason?
- Cloud cover
 - Satellite imagery shows storm activity nearby.
 - Flight video shows that at times of magnetic peak, we did not move through a cloud.
- Atmospheric layers
 - Data suggests magnetic peaks correspond with changing atmospheric layers.

Cloud Cover Analysis

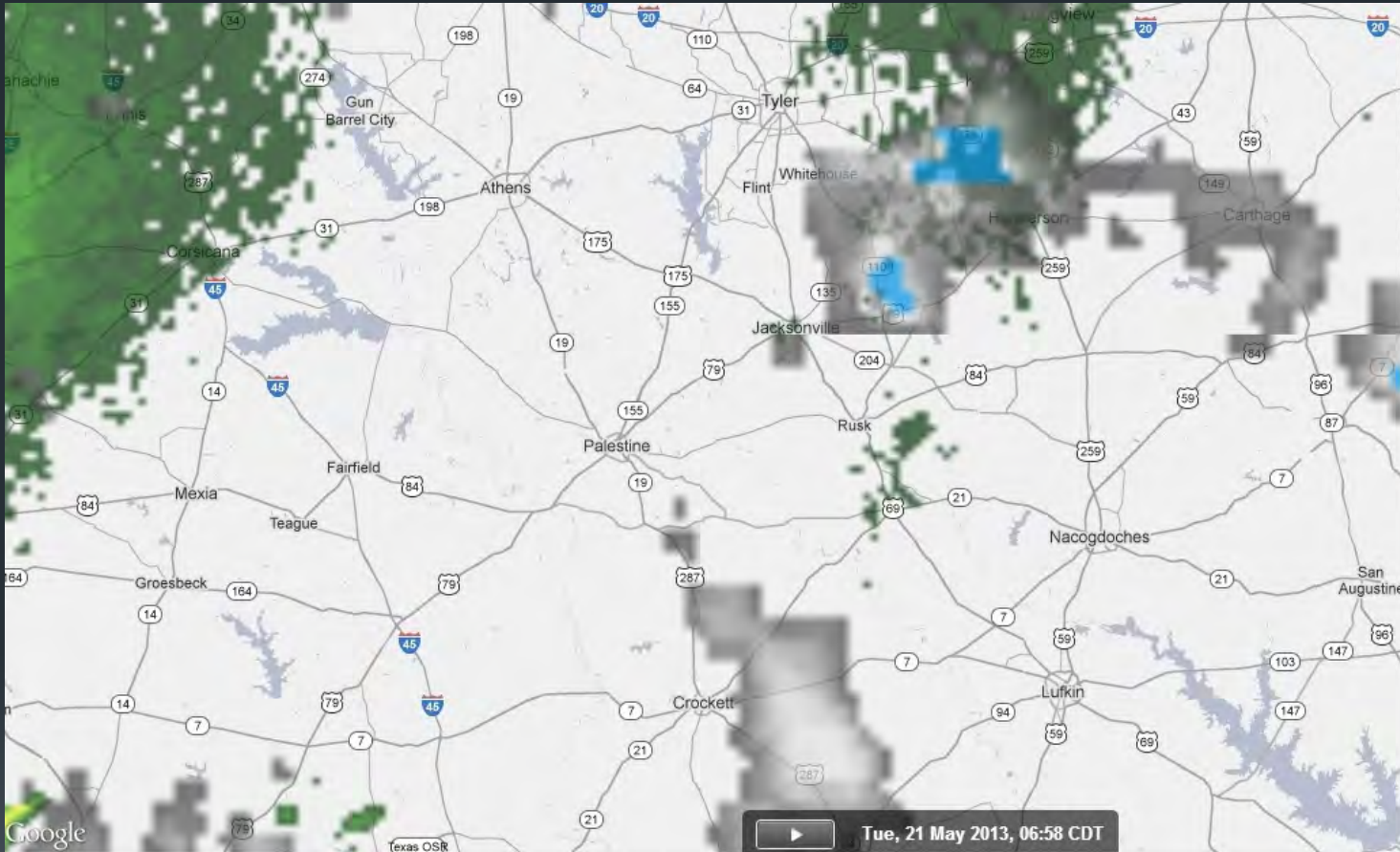

- Local weather reports show cloud cover in the area of flight.

Cloud Cover Analysis



- In-flight video shows no cloud layer at magnetic peaks.

Atmospheric Layers

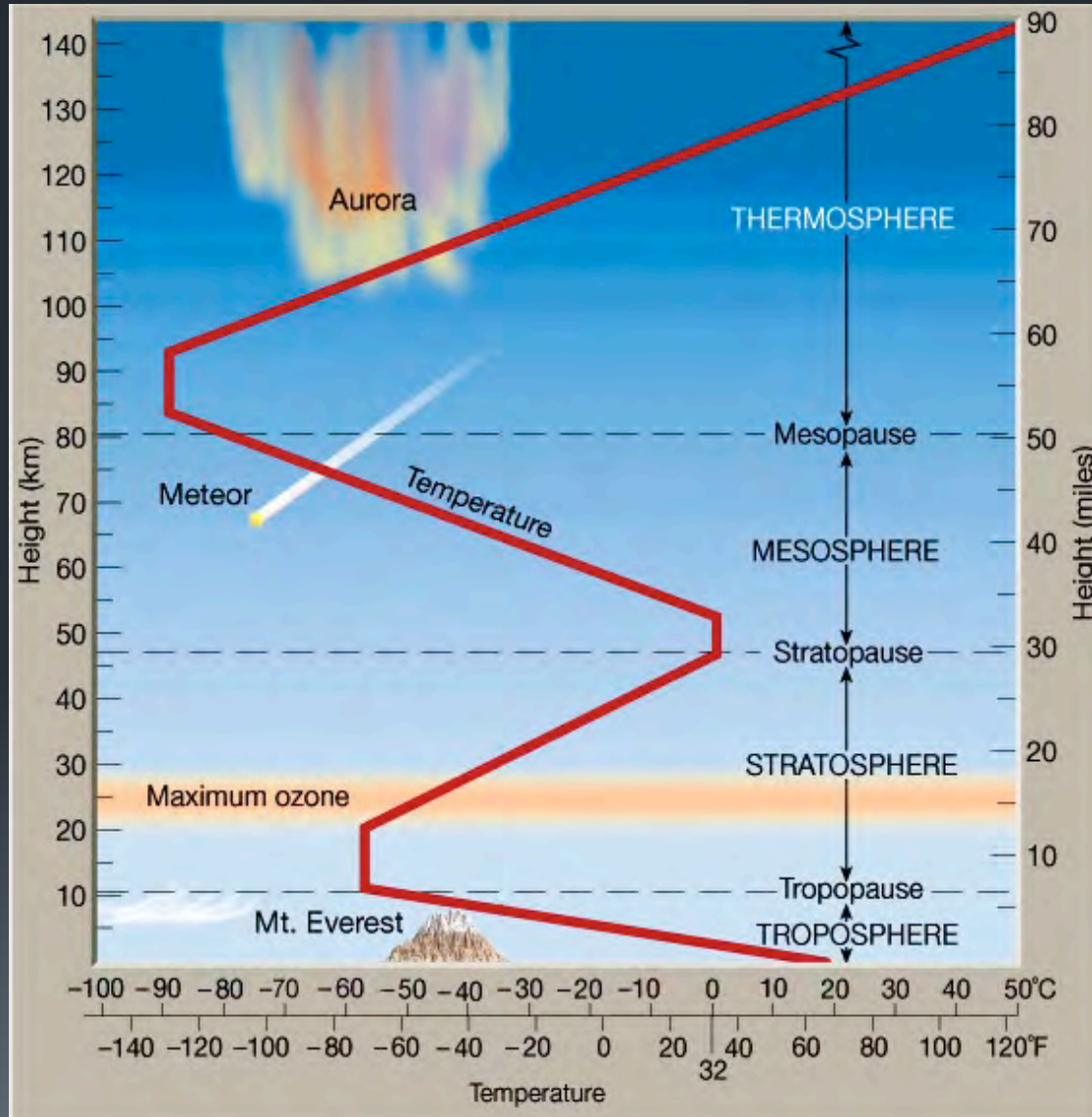

Temperature Analysis

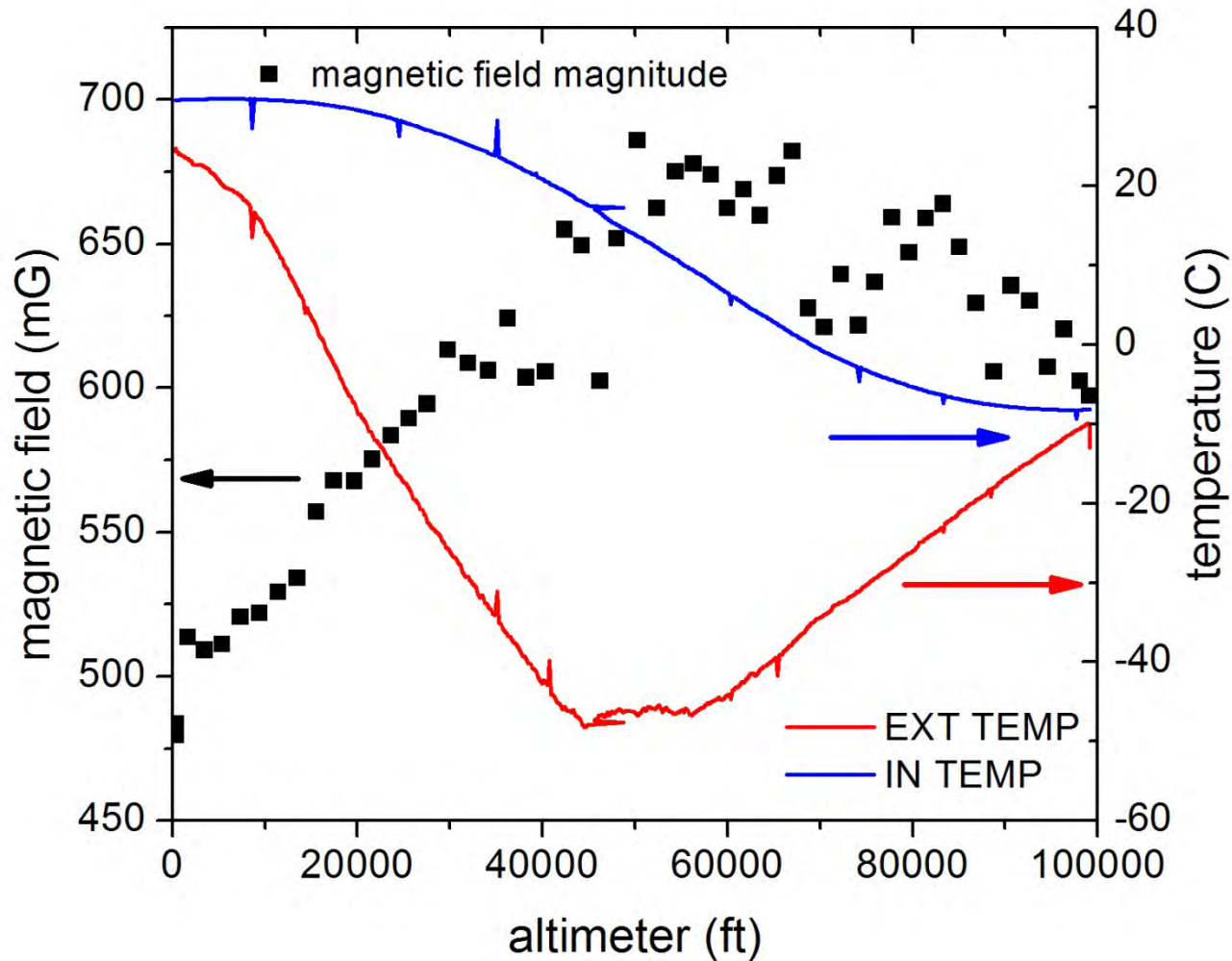

Temperature Analysis

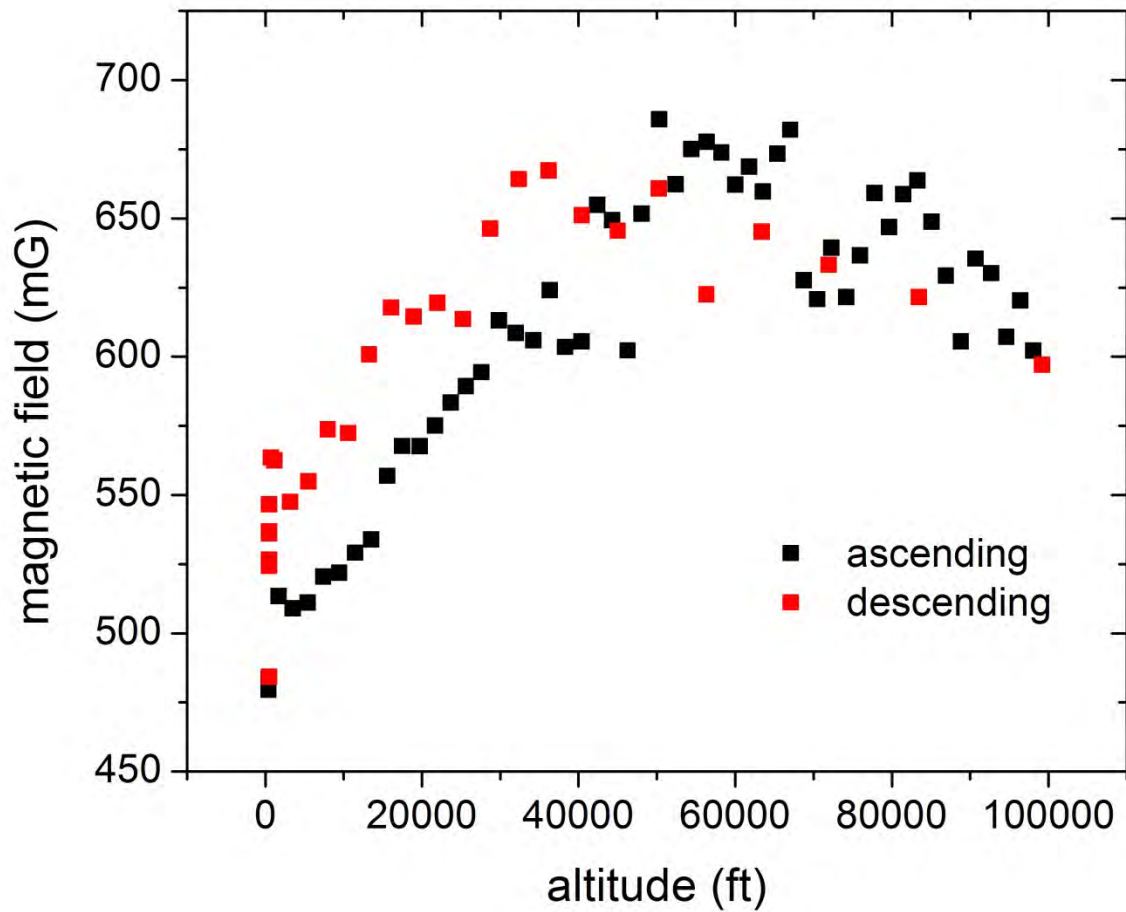

Possible Correlations



- Maximum magnetic field detected near tropopause, the coldest point in the balloon's flight.
- Internal temperature seems to have affected the magnetic sensor dramatically.
- On ascent, the magnetic field peaked immediately above the tropopause. On descent, the magnetic field peaked immediately below the tropopause.
- This means the peak magnetic field does not correspond to a specific altitude, but rather is a function of internal temperature which is insulated.

Solar Activity?



- NOAA reported no geomagnetic disturbances due to the sun on flight date.
- All data seems to correlate with ambient temperature changes.
- Solar activity appears to have had no measurable effect on the data.

Model Predictions

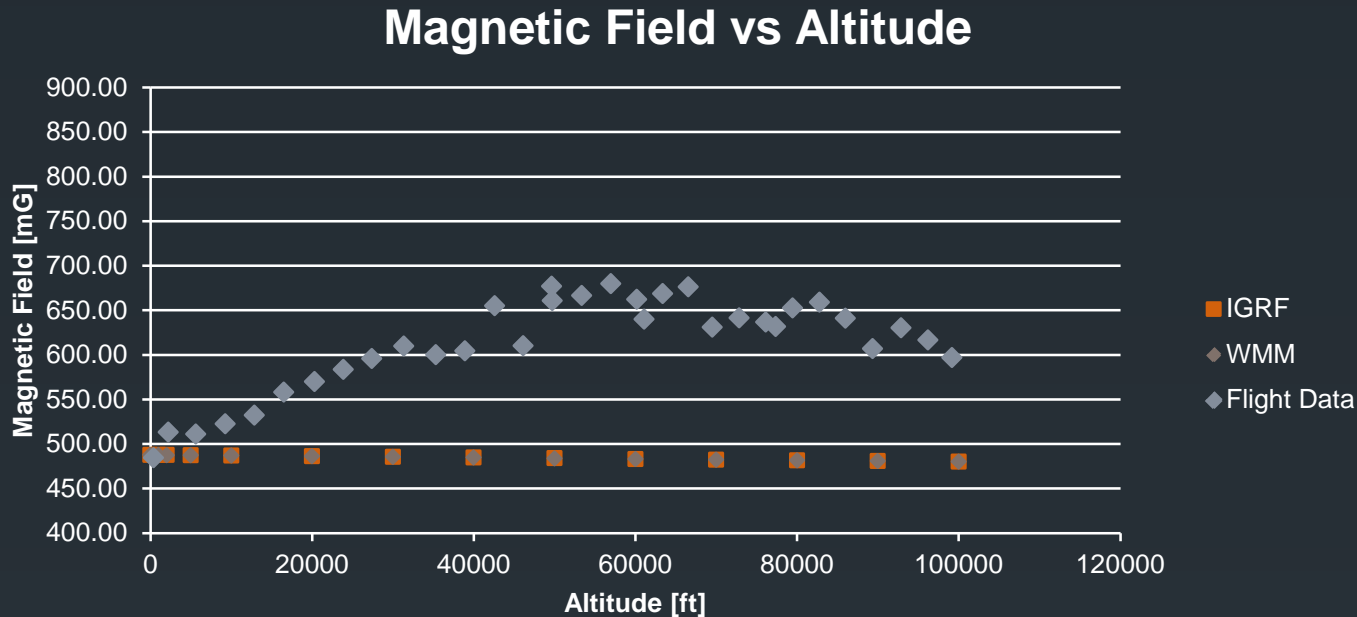

- Model predicted a linear, 10mG decrease between launch and apex.
- Data shows increase towards tropopause, decrease away from it.
- Recorded data shows ~150mG difference between launch and peak magnetic field.

Conclusions



- Payload design was sufficient for protection of equipment.
- We would not have been able to measure the radial distance effect on the geomagnetic field due to the insufficient intrinsic resolution of our sensor.
- We were able to determine an undocumented temperature dependence in the magnetic field sensor used.

Conclusions



- Influence of nearby weather conditions is not entirely clear. Electrical and thus magnetic influence is probable.
- Solar influence is not present or unclear.
- To compare against mathematical models, a more sensitive device is required. Atmospheric conditions are also highly critical.

Q & A



Additional Data -Thermal Results

Temperature vs Time

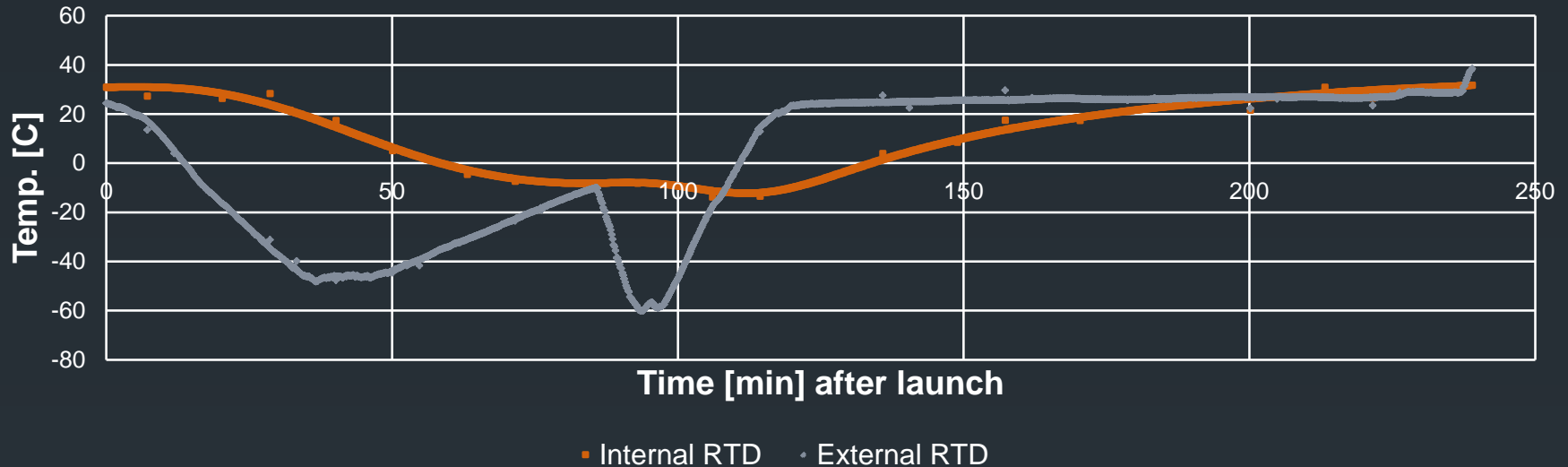

- Lowest temperature inside payload:
 - -10°C
- Lowest ambient temperature recorded:
 - -60°C

Additional Data – Cloud Cover at Launch

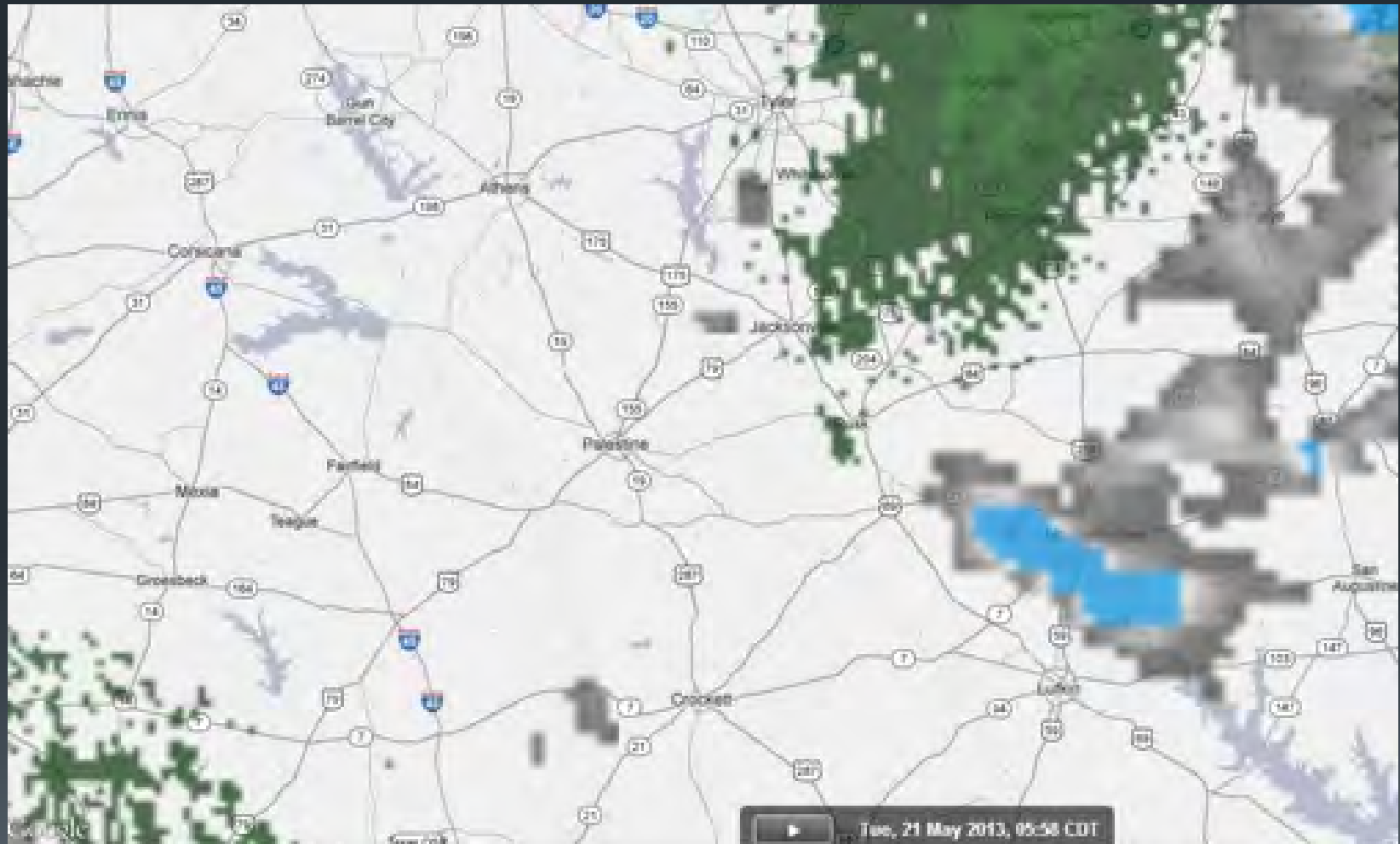

Additional Data – Cloud Cover at Impact

